

THIS COPY IS PROVIDED ON A RESTRICTED BASIS AND IS NOT TO BE USED IN ANY WAY DETRIMENTAL TO THE INTERESTS OF PANDUIT CORP.

Material	High Conductivity Seamless Copper Tube
Plating	Electro-Tin
Wire Size	6 AWG
Wire Type	Stranded Copper; Class B: Compact, Compressed or Concentric, Class C: Concentric
Wire Strip Length	7/8 in.
Stud Size	1/4 in.
UL Listed Wire Connector	Yes, for applications up to 35kv. Consult cable manufacturer for voltage stress relief instructions with applications greater than 2000 volts.
UL Temperature Rating	90° C
C.S.A Certified Wire Connector	Yes
Panduit Color Code on Barrel	BLUE
Panduit Die Index No. on Barrel	P24
Alternate Industry Die Index No. () on Barrel	(7)

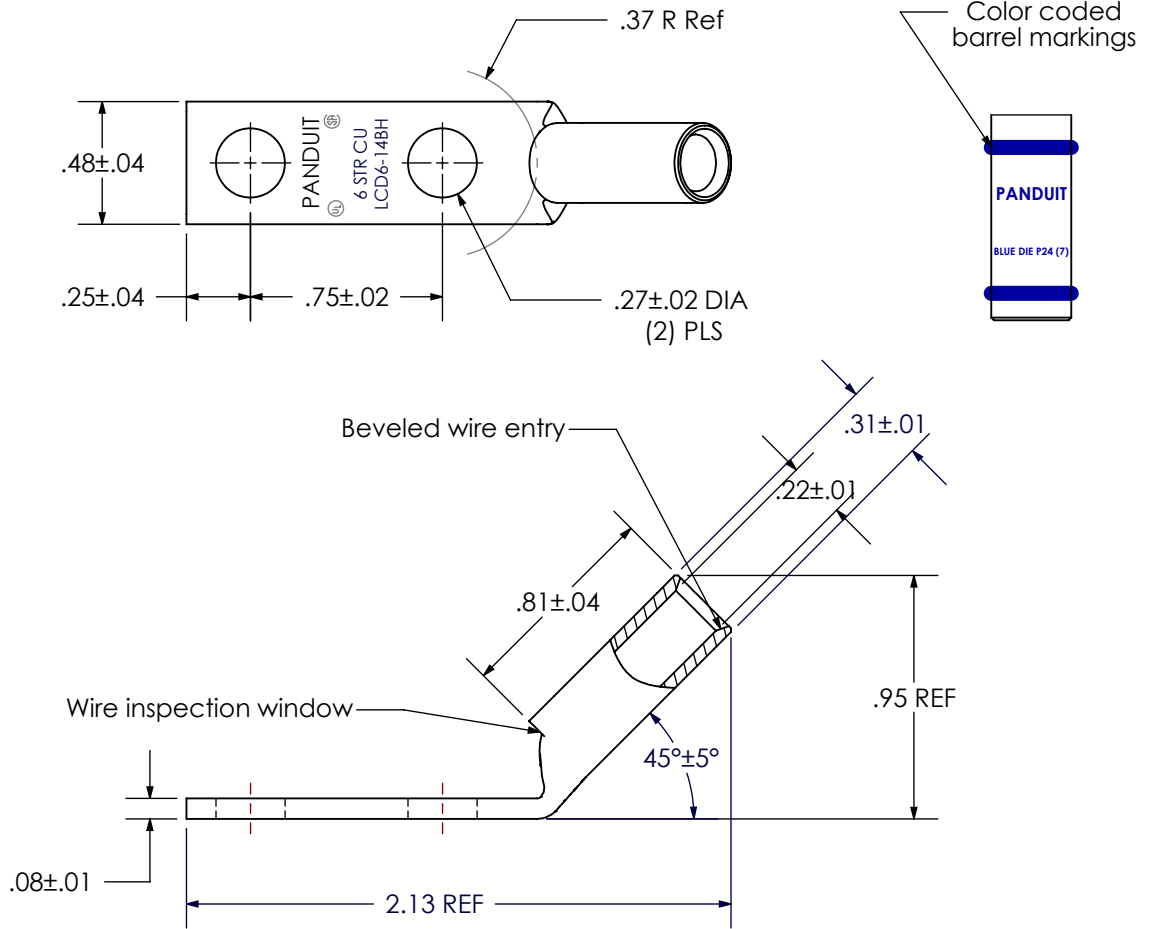

REV	DATE	BY	CHK	APP	DESCRIPTION	ECN
03	9-23	JHNU	JHNU	MRWA	B. STAMP LOCATION DRAWING CHANGE DATE: 7-12	135035
02	9-23	JHNU	JHNU	MRWA	A. REVISED STAMPING LOCATION: UL & CSA LOGOS, PANDUIT MOVED IN BETWEEN STUD HOLES	134633

PANDUIT CORP. TINLEY PARK, ILLINOIS

LCD6-14BH-L
Copper Lug - Two-Hole, Standard Barrel, 45° Angle Tongue

SCALE N/A DRAWING NO / CAD FILE LCD6-14BH-CUST